

# 11020 Bead Breaker

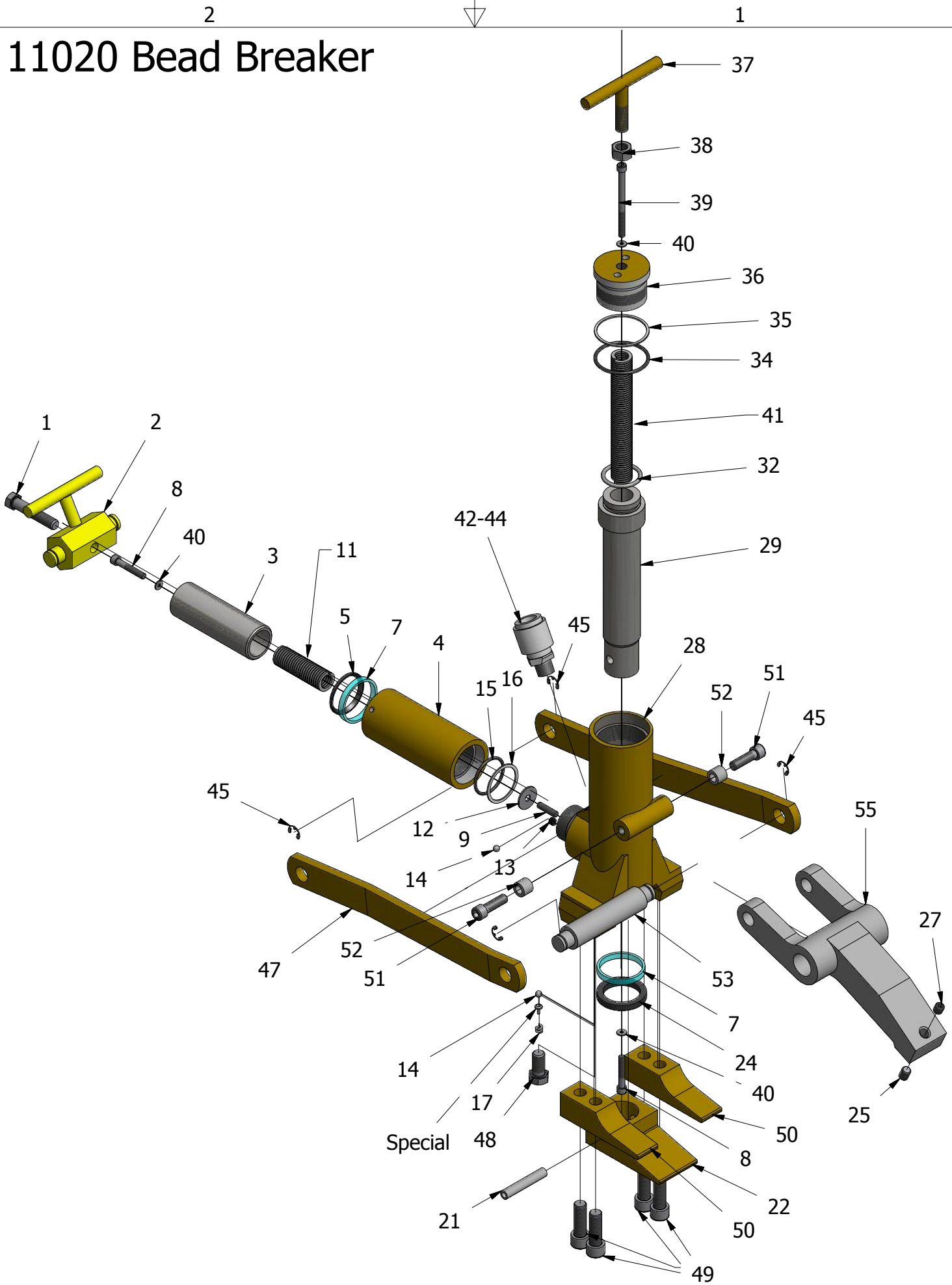

2

1

B

B

B

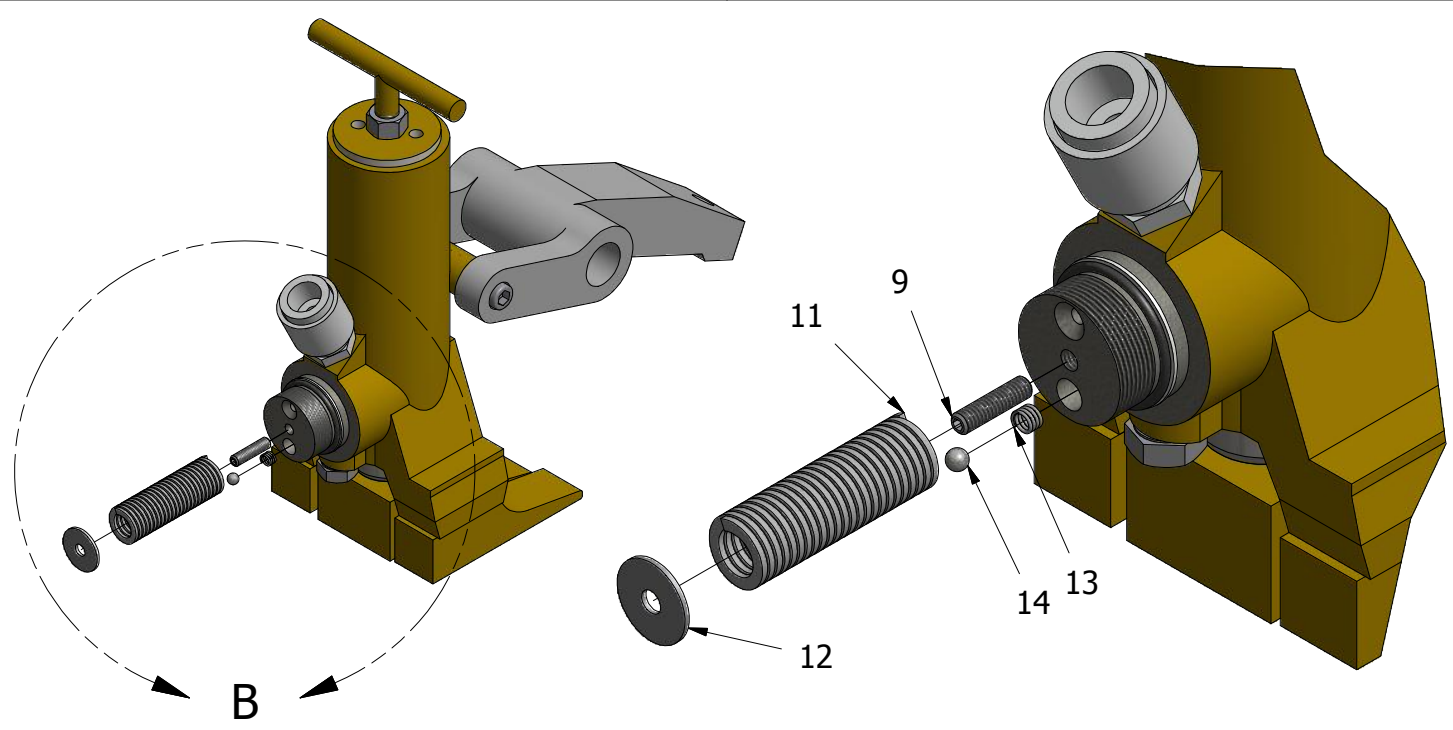

DETAIL B  
SCALE 1 / 2

A

A

A

A

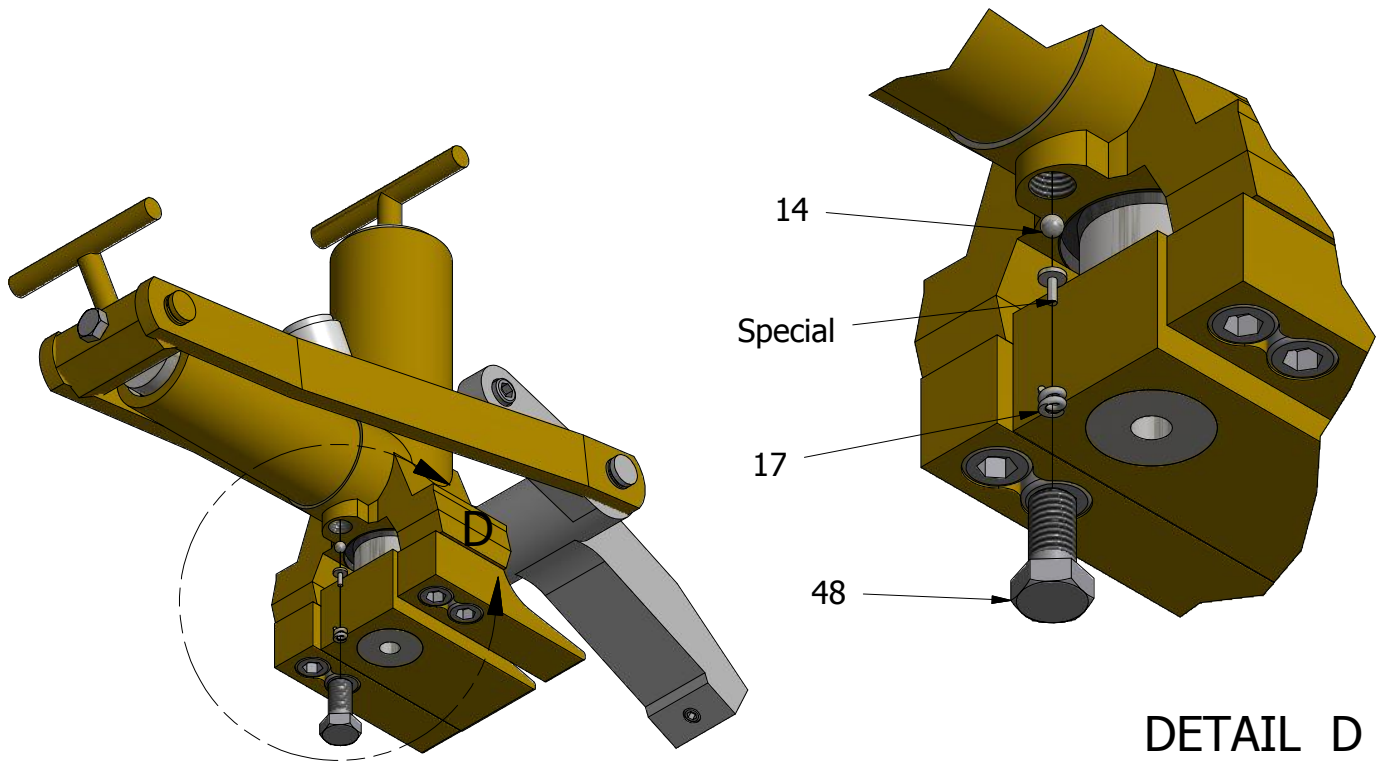

DETAIL D  
SCALE 1 / 2

2

1



## 11010 PARTS LIST

ITEM	QTY	PART NUMBER	DESCRIPTION	
1	1	11010-001	Screw, Hex Hd. Cap (7/16-14 x 2); Torque to 30/40 Ft.Lbs	
2	1	11010-002	Handle, Strap Pivot	
3	1	11010-003	Piston, (Single Jaw)	
4	1	11010-004	Body, Cylinder (Single Jaw); Torque to 125/140 Ft.Lbs	
5	2	11010-005	Rod Wiper	
7	2	11010-007	U-Cup	
8	2	11000-013	Screw, Soc Hd (1/4-20 x 1-1/4), Torque to 215/140 Ft.Lbs	
9	1	11010-009	Screw, Set (1/4-20 x 1)	
B 11	1	11010-011	Spring, (0.83 OD x 1.3 WS); With Retainer	B
12	1	11010-012	Washer, Special (1.00 x .26)	
13	1	11010-013	Spring, (.36 OD x .50 x .05 WS)	
14	2	11010-014	Ball, (1/4 in. Diameter, Steel)	
15	1	11010-015	O Ring, (1.62 x 1.37 Nitrile)	
16	1	11010-016	Washer, Backup (2.00 x 1.75)	
17	1	11010-017	Spring, (.32 OD x 1.20 x .08 WS)	
21	1	11020-021	Pin, Roll (.38 x 2.25)	
22	1	11020-022	Claw, Machining	
24	1	11010-024	Wiper, Rod (2.00 x 1.50 URE)	
25	1	11010-025	Screw, Set (3/8-16 x 1/2)	
27	1	11010-027	Screw, Set (3/8-16 x 3/8)	
28	1	11010-028	Body, Bead Breaker	
29	1	11010-029	Piston, Cylinder	
32	1	11010-032	Ring, Retainer (internal 1/31 ID)	
34	1	11010-034	O Ring (2.00 x 1.75)	
35	1	11010-035	Washer, Backup (2.00 x 1.75)	
36	1	11010-036	Plug, End (Torque to 14/225 Ft.Lbs)	
37	1	11010-037	Handle	
38	1	11010-038	Nut, Hex Jam (1/2-13)	
39	1	11000-023	Screw, Soc Hd (1/4-20 x 2-1/2, Torque to 90/110 In.Lbs)	
40	3	11000-022	Washer, Copper (.37 x .25)	
41	1	11010-041	Spring, (0.83 OD x 5.00 x .13 WS); With Retainer	
45	4	11010-045	Ring, Retainer External	
A 47	2	11010-047	Strap	A
48	1	11010-048	Screw, Cap (9/16-18 x 1-1/8)	
49	4	11010-049	Screw, Soc. Hd. (1/2-13 x 1-1/4)	
50	2	11020-050	Tooth, Replaceable	
51	2	11010-051	Screw, Soc. Hd. (1/2-13 x 1-1/4)	
52	2	11010-052	Spacer	
53	1	11010-053	Pin	
55	1	11020-055	Jaw. Single	
42-44	1	11010-042-044	Fluid Line Attachment	
Special	1	11010-060	Ball Cap : Optional	

